



Journal of Co-operative and Business Studies (JCBS)
Vol. 6, Issue 2, November 2021 ISSN: (Online) 2714-2043, (Print) 0856-9037
Full Issue and Text Available at: <http://www.mocu.ac.tz>

INTERNAL DRIVERS OF ECOPRENEURSHIP AMONG FOOD AND BEVERAGE INDUSTRIES IN TANZANIA

Mohamed Buzohera¹ and Salum Matotola²

¹The University of Dodoma, Department of Business Administration and Management.
Email: Issabtz@gmail.com

²The University of Dodoma, Department of Business Administration and Management
Email: Matotola2015@gmail.com

ABSTRACT

The concept of ecopreneurship is evolving due to necessity to address the sustainability challenges particularly on the environment grounded on industrial pollutions. Thus, several researches have been committed to address sustainability challenges through investigating mechanism for enhancing ecopreneurship implementation in different context of nations. In this path, this study focused to examine the influence of internal drivers on the implementation of ecopreneurship headed for addressing sustainability challenges. This is empirical study incorporated (102) small scale ecopreneurs operating in the Tanzania food and beverage industries. The study was directed to test five hypotheses of internal drivers namely; finance knowledge, internal stakeholders, motivation and researches on influencing ecopreneurship implementation. The results of the study found that, four among the five tested drivers had significant and positive influence on ecopreneurship implementation; the significant drivers consist of finance, knowledge, internal stakeholders and researches. Thus, ecopreneurship implementation can be enhanced through financing ecopreneurship activities, increasing employee knowledge on environment, upholding stakeholders concern on sustainable industrial practices and researching information regarding environmental-friendly products, along with eco-technology. Conversely, motivation had insignificant influence on ecopreneurship implementation. Therefore, the study recommends on initiatives to enhance ecopreneurship implementation through significant drivers and so addresses the sustainability challenges sourced from unsustainable industrial practices.

Keywords: Internal Drivers; Ecopreneurship Implementation; Sustainability; Food and Beverage Industries.

1.0 INTRODUCTION

The discussion on the relationship between ecopreneurship and sustainability emerged during the 1990's when the concept of environmental entrepreneurship and ecopreneurship emerged (Haldar, 2019; Lopez, Martinez, Joaquin, and Lorente, 2019; Schaltegger, 2002). According to background, studies conducted by Schaltegger (2002) the concept of ecopreneurship was formed by combination of two words, 'ecological' (eco) and 'entrepreneurship' (preneurship). Schaltegger (2002) discussed ecopreneurship as the 'entrepreneurship through an environmental lens'. Therefore, ecopreneurship is defined through discovery of opportunities that help to protect the environment in pursuit of sustainability paradigm across economic, social and environmental dimensions.

Furthermore, according to background studies of ecopreneurship cited in the work of Rusmini, Taufikurohmah, and Sianita (2019), the concept of ecopreneurship was explained by three major entrepreneurial practices namely eco-

COPYRIGHTS

Licensed under a Creative Commons Attribution-Non Commercial 4.0 International License



opportunity, eco-commitment and eco-innovation. Based on these practices, researchers have underlined the positive influence of ecopreneurship practices on the attainment of sustainability grounded on the outcome of implementation on economic, social and environmental aspects. This positive influence of ecopreneurship is associated with the management of environmentally friendly operations in materials, products, process and marketing activities directed towards better sustainability performance (Halder, 2019; Panackal, Singh, and Sharma, 2016).

In connection to the positive influence of ecopreneurship on sustainability, several strategies have been presented towards enhancing ecopreneurship implementation. Some of the prominent strategies involve advocacy presented in the international treaties such as the Convention on Biological Diversity (CBD, 1996), United Nations Framework Convention on Climate Change (UNFCCC, 1992) and the ongoing seventeen Sustainable Development Goals (SDGs, 2015-2030), particularly goal number nine (9) on achieving sustainable industrialization and fostering innovation (UN, 2015). Based on the advocacy in the international treaties, several countries have conducted policy formulation and development intended to enhance the implementation of ecopreneurship practices.

With respect to enhancing ecopreneurship implementation, several scholars have conducted studies to investigate the implementation of ecopreneurship and emphasise on strategies through several drivers. The work of these scholars include environmental study by Han, Wang, and Yan (2019) who asserted on the influence of internal stakeholders including industrial environmental leadership on enhancing employees' motivation towards eco-related practices and further submission on the influence of external stakeholders including customers, suppliers and government policies as well as regulations towards encouraging implementation of environmental practices.

Furthermore, other recent studies conducted on the investigation of ecopreneurship drivers include the work of Zhang (2019) who concluded on the significance of stakeholders pressure particularly on influencing firms implementation of eco-related practices. In addition, other cited drivers in the literatures includes financial capability (Del Río, Romero and Peñasco, 2017), knowledge on sustainability (Shepherd and Patzelt, 2015), as well as the utilisation of the activities of eco-research and development (Del Río *et al.*, 2017).

Nevertheless, despite the scholar's work on identification of the drivers for enhancing implementation of ecopreneurship, there is existence of stalemates regarding to the significances of the drivers when are measured on different context of nations. With respect to this, empirical studies have shown inconsistency results on these drivers towards influencing implementation of ecopreneurship related practices in different perspective of nations (Kushwaha and Sharma, 2017; Bruin, 2016).

The inconsistent results are evidenced in some background studies on the drivers of ecopreneurship including Silverman, Marshall, and Cordano (2005) in New Zealand and the United States wine industry. This study found that motivation and external stakeholder pressures were not significant drivers in New Zealand, whereas the same was found to be stronger determinants in the United States wine industry. Furthermore, a study conducted by Ceptureanu, Orzan, Bordean, and Radulescu (2017) in the Romania Polyvinyl Chloride (PVC) joinery industry on factors influencing implementation of sustainable opportunities established that, market orientation and sustainable entrepreneurial orientation extensively influence the implementation of sustainable opportunity orientation, whereas knowledge, motivation, and awareness of sustainable development have insignificant influence. However, study findings from Ceptureanu *et al.*, (2017) were contrary to the findings of Shepherd and Patzelt (2015) that were conducted in Germany and established that knowledge and motivation had significantly influenced the implementation of sustainable ecopractices.

Based on the inconsistency of the results in several empirical studies concerning drivers influencing the implementation of ecopreneurship practices, it can be hypothesised that most of the drivers are limited in scope in enlightening the implementation of ecopreneurship in different perspectives of nations. With respect to this, the question of how to enhance the implementation of ecopreneurship practices towards sustainability, specifically in the context of developing countries such as in Tanzania persists to be a vital concern.

The question of how to enhance the implementation of ecopreneurship is grounded on the empirical evidence in the context of Tanzania which has shown limited implementation of ecopreneurship practices among many industrialists. The limited ecopreneurship is indicated by studies that have reported on the increasing generation and discharge of industrial waste with statistics of 678.9 to 689.5 thousand tonnes in the year 2013 and 2015 respectively

(URT, 2018). Also, evidence from an industrial assessment conducted by the United Republic of Tanzania (URT, 2017) shows the dominance of unsustainable industrial practices in many industries which include deprived management of waste in water and air. Further, unsustainable practices were observed on indiscriminate disposal of liquid and solid wastes, lacking of environmental safeguards, uncertified products, and lacking environmental-friendly industrial processes.

Furthermore, according to the status of sustainability provided by the Environmental Performance Index (EPI, 2020) involving (180) countries worldwide, Tanzania is ranked among the lowermost sustainable countries given overall ranked position of environmental performance in the number (150) among (180) countries. Specifically, the ranks involve position (101) on air quality and (133) waste management. Accordingly, the reported statistics provide substantial empirical evidence indicative of a noticeable challenge of sustainability, particularly in the environment, which is associated with the limited implementation of ecopreneurship practices.

Therefore, grounded on the existence of sustainability problems due to limited implementation of ecopreneurship practices in Tanzania industries and mentioned inconsistency of information in the literature on drivers of ecopreneurship in the different context of nations. This study was designed to investigate significant drivers to the implementation of ecopreneurship practices. The results of the study may possibly develop an understanding of the significant drivers for ecopreneurship implementation in the Tanzania context, and so appropriate implementation strategies can be undertaken.

2.0 LITERATURE REVIEW

2.1 Theoretical Literature and Research Hypothesis

This study is formulated along the inference that implementation of ecopreneurship practices is associated with the internal firms' decisions and capabilities. In this respect, the study hypothesised implementation of ecopreneurship being influenced significantly by internal drivers. Therefore, it became relevant to have guidance from theories explaining ecopreneurship and internal industrial factors as key drivers enhancing ecopreneurship implementation.

Three theories have been deduced in this study including Schumpeterian entrepreneurial theory (1934) in explaining entrepreneurship, Huber (2000) ecological modernisation theory in explaining ecopreneurship. Furthermore, resource-based view by Barney (2001) on strategic resources of the firms' has been useful in explaining the internal drivers for the implementation of ecopreneurship. For that reason, selection of multiple theories provided useful understandings regarding implementation of ecopreneurship practices in the setting this study.

The Schumpeterian theory provides the theoretical basis for understanding of ecopreneurship practices, given that ecopreneurship concept is formed by two words specifically ecology and entrepreneurship. According to Schumpeter (1942) entrepreneurship conveys changes, forging new and original ways of doing things that compete with and often overhauled the traditional way of doing things. According to Schumpeter, the new way of doing things implies innovations which he stated to be the central role of entrepreneurs. The Schumpeterian innovations were deduced in five scopes including new source of materials, new product, new market, new technology and new organization of industry.

With respect to this, innovation involves important aspects of identification of opportunities to innovate and commitment of entrepreneurs to innovate. It is with this view that, scholars including Rusmini, Taufikurohmah and Sianita (2019) proposed ecopreneurship model with three practices namely; eco-opportunity orientation, eco-innovation and eco-commitment. In this regard, the entrepreneurial innovation is considered as the solution towards attainment of sustainability. Therefore, industrialists' actions to implement ecopreneurship involve innovations in the production method, technological development, product/service distribution system, or a new organisational system with sustainability consideration.

Similarly, the ecological modernisation theory provides the foundation for ecopreneurship through understanding of the aspects of ecology and hence integrates business activities with environment consideration together with innovation leading to sustainable business operations (Longhofer and Jorgenson, 2017). This theory is based on the facts that most of the pressing environmental problems were caused by industrialisation and modernisation. With this respect, the theory suggested solution of environmental problems through more industrialisation and modernisation i.e. super industrialisation and neither demodernisation nor deindustrialisation (Pushpakumara, Atan, Khatib, Azam and Tham, 2019).

In his view, Pushpakumara, *et al.*, (2019) believed on the role of technological innovations in environmental transformation especially in the sphere of industrial production. Thus, innovative transformations may perhaps involve clean technologies, eco-goods and services, and the interplay of various factors including firms' capabilities which foster or hamper such innovations. Therefore, the associations between environmental innovations through implementation of ecopreneurship and attainment of sustainability are being established.

Regarding to the drivers to the implementation of ecopreneurship, the development of the theory of resource-based view "RBV" by Barney (2001) provided essential guiding framework. The popularity of the theory is mostly originated from the strategic management discipline in explaining strategic usage of inimitable organisation resources towards competitiveness and superior performance. The theory is guided by two key assumptions. First, resources are the determinants of firms' performance and second that resources of the firms must be rare, no substitutable and inimitable.

Therefore, the resource-based view attributes advantages in an industry to control over bundles of unique material, human, organisational, location and skills towards better performance. Given that, this study is aiming at analysing significance of internal driven capabilities of the industries on implementation of ecopreneurship. The RBV theory became relevant in explaining the strategic control of the resources and capabilities of the industries towards implementation of ecopreneurship practices.

Based on the theoretical inference from RBV, it is hypothesised that, implementation of ecopreneurship practices is determined by the control of the internal resources of the industries. Thus, internal factors of the industries significantly influence implementation of ecopreneurship practices. However, based on the inconsistency of the empirical findings regarding to the significance of drivers for ecopreneurship implementation, a vital question regarding to which internal factors can significantly enhance implementation of ecopreneurship practices. Therefore, this study attended this question through investigation of the internal factors influencing ecopreneurship implementation. In this regard, this study established five null hypotheses of internal drivers to be tested as follows:

- i. *Ho: There is no relationship between finance and implementation of ecopreneurship practices in the selected industries*
- ii. *Ho: There is no relationship between knowledge and implementation of ecopreneurship practices in the selected industries*
- iii. *Ho: There is no relationship between internal stakeholders and implementation of ecopreneurship practices in the selected industries*
- iv. *Ho: There is no relationship between motivation and implementation of ecopreneurship practices in the selected industries*
- v. *Ho: There is no relationship between research and implementation of ecopreneurship practices in the selected industries*

2.2 EMPIRICAL LITERATURE REVIEW

2.2.1 Ecopreneurship practices in developing countries

The implementation ecopreneurship practices are associated with the developments of environmental management approaches employed over period of time particularly in attaining sustainability. This development of industrial environmental approaches has involved transition from end of pipe technologies, cleaner production into ecopreneurship practices. As it was provided by Hens *et al.*, (2018) cleaner production (CP) involve preventive and continuous strategies aiming to enhance efficiency of environmental performance and reduction of industrial costs particularly in the areas of products, process and services offered. In this regards, the concentrations of cleaner production is associated with the commencement of the ecopreneurship concept mainly in the 2000's era cited in the background study of ecopreneurship conducted by Schaltegger (2002).

The concept of ecopreneurship is associated with cleaner production and sustainability because it focuses on ecological and economic sustainability through green production and green marketing activities towards solving environmental problems (Ljungkvist and Andersén, 2021). Therefore, the advantages of ecopreneurship on sustainability in the social, economic and environment have raised global concern towards efforts to enhance the implementation of ecopreneurship practices in industries. Thus, so far there is a wide consensus among scholars regarding to the implementation of ecopreneurship practices in industries intended for attaining sustainability.

However, in spite of the concern on the implementation of ecopreneurship practices in industries, empirical evidence shown limited ecopreneurship implementation among many industrialists particularly in the developing countries including Tanzania. For instance, several empirical studies conducted in Tanzania on sustainable industrialisation reported on existence of many manufacturing industries with unsustainable practices particularly among food and beverage manufacturing industries which mentioned to be among lead industries in contributing environmental pollution in the air, water and land (URT, 2017; Mwegoha and Kihampa, 2010).

Furthermore, the status of limited ecopreneurship implementation in Tanzania is similar with many other African countries. With respect to this, it was indicated in the study by Fayiga, Ipinmoroti, and Chirenje (2018) that most countries in Africa particularly in countries such as Zimbabwe, Kenya, Nigeria, and Ghana experience challenges of unsustainable practices including industrial activities which have results into environmental pollution specifically in water, air and soil. Therefore, it is substantial to deliberate on investigating the implementation of ecopreneurship practices in many Africa countries including Tanzania. In this direction, this study intended to examine the implementation of ecopreneurship practices through investigation on the significant drivers influencing implementation and so appropriate implementation strategies can be undertaken.

2.2.2 Drivers for the implementation of ecopreneurship practices

The increasing alertness to the problems of sustainability sourced by industrial activities has streamlined efforts toward addressing implementation of sustainable ecopreneurship practices in industries. The efforts include the work of several scholars 'who have investigated relationship between drivers and implementation of sustainable ecopreneurship among industrialist. Nevertheless, this relationship between drivers and ecopreneurship implementation is widely debatable among scholars. The debate is based on empirical literatures which have discussed the applicability of identified drivers in different context of nations based on the conflicting findings where many of the identified drivers have shown diverse significance of influence when quantitatively measured in different nations.

The drivers have largely been categorised into two groups' specifically internal and external drivers. The internal drivers include effectiveness of firm internal capabilities such as financial capacity (Del Río *et al.*, 2017), motivation towards sustainability (Han *et al.*, 2019). Additionally, other cited drivers include knowledge on sustainability (Shepherd and Patzelt, 2015) and further on the utilisation of activities of eco-research and development (Del Río *et al.*, 2016).

The external drivers on the other hand include influence of market orientation for eco-products and technology (Ceptureanu *et al.*, 2017), adherence to policies and regulations (Hörisch, 2015), influence of stakeholders (Zhang, 2019) and technological availability (Santini, 2017). With respect to the significances of drivers on influencing ecopreneurship implementation, empirical studies have shown insufficient information on these drivers towards influencing implementation of ecopreneurship practices mostly in the context of different nations (Kushwaha and Sharma, 2017; Bruin, 2016). The insufficient of information on drivers is indicated by empirical findings of diverse results on the significance of many of the identified drivers when tested in different nations. For instance, a study by Silverman, Marshall, and Cordano (2005) in New Zealand and United States wine industry found that motivation and external stakeholder pressures were not significant drivers in New Zealand whereas the same were found to be stronger determinants in United States wine industry.

Furthermore, other studies which reported on the inconsistent of the results include the work of Ceptureanu *et al.*, (2017) in Romania, this study found that market orientation significantly influence implementation of sustainable opportunity. However the findings of Ceptureanu *et al.*, (2017) shown that knowledge, motivation and awareness of sustainable development had insignificant influence on implementation of ecopreneurship. However, these findings from Ceptureanu *et al.*, (2017) were conflicting with the findings from other study conducted by Shepherd and Patzelt (2015) in German which established that knowledge and motivation had significantly influenced the implementation of sustainable ecopractices.

Based on the inconsistency of the results on significance of drivers, Bruin (2016) contended that ecopreneurs built in USA and Canada may vary significantly from those required in least developed Sub-Saharan countries due to context base factors. Furthermore, most of the cited empirical studies which have investigated drivers for

ecopreneurship implementation were based on developed countries. In this regard, there is limited information on drivers for the ecopreneurship implementation particularly in the context of the African countries including Tanzania. Grounded on this background, this study was designed to examine the influence of drivers on ecopreneurship implementation. The purpose of this investigation was to disseminate vital information for initiatives towards enhancing ecopreneurship implementation particularly in Tanzania context.

3.0 METHODOLOGY

This study was conducted in six (6) regions of Tanzania mainland namely; Dar es Salaam, Arusha, Dodoma, Singida, Mwanza and Kagera as spotted with red colour in the Figure 1. The regions were purposely selected to accommodate relevance of addressing limited implementation of ecopreneurship practices which results into sustainability problems. This study was conducted in the food and beverage industries. The food and beverage sector was indicated to be vital in Tanzania industrialisation in terms of diversity and activity (Wangwe *et al.*, 2014). According to the literature on industrial mapping conducted by Tanzania National Bureau of Statistics (NBS, 2016) on census of industrial production (CIP), the selected regions have been reported to be among the established industrial lead in Tanzania. In this census, the region of Dar es Salaam was reported with a concentration of beverage industries. While, Dodoma and Singida regions were reported with concentration of oilseeds industries. Furthermore, Arusha was reported with concentration of flour mills industries. Additionally, Kagera and Mwanza regions were reported with concentration of dairy, tea and coffee industries. Furthermore, in connection with the study problem, the selected regions were cited to contribute to the sustainability problems associated with industrial pollution. Therefore, the selected regions represented a vital study area in addressing sustainability through implementation of ecopreneurship practices presented in Figure 1.

This study implemented a cross-sectional research design. The cross-sectional research design is defined as a quasi-experimental among substance matters design from which, the observation is performed by researcher in a single moment in a short time advantage (Zangirolami-raimundo and Oliveira (2018). Therefore, survey was conducted to the unit of enquiry which were managers of selected industries. The survey method was conducted to collect primary data through self-administered questionnaires which were distributed to unit of inquiry who were ecopreneurial industries.

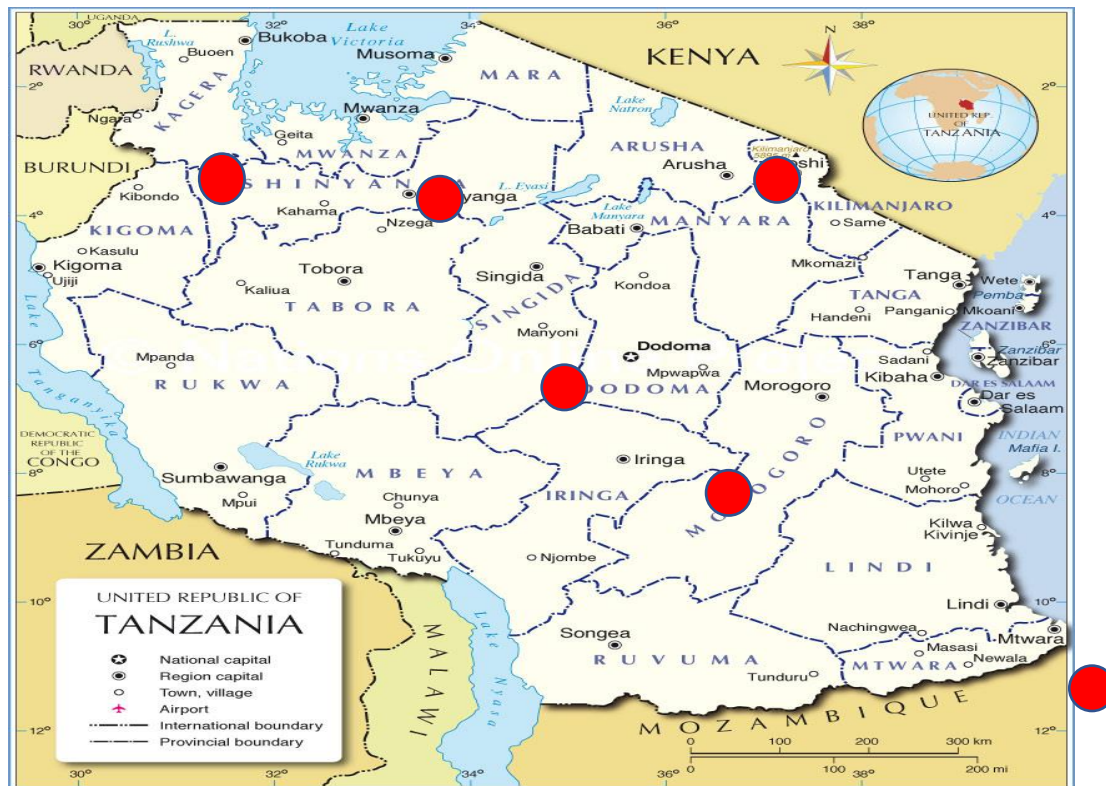

Figure 1: Tanzania Map showing the Study Regions

This study employed purposive and census sampling design. The purposive sampling in this study was useful in the selection of food and beverage industries. This selection followed the attention of the global sustainability as mentioned in the Sustainable Development Goals SDG's (2015-2030) particularly on food security, nutrition, sustainable agriculture and health lives (UN, 2015). For that reason, health-oriented products in the food and beverage were considered to be significant areas of study for addressing sustainability through investigation of the drivers to the implementation of ecopreneurship practices. Subsequently, list of ecopreneurs was generated from certified industries dealing with the selected products based on the list obtained from the Tanzania Bureau of Standards TBS under "quality mark category" (2019). The list had total number of 123 of eco-certified industries which were considered suitable to be surveyed. Afterwards, six (6) regions were purposive selected to be involved in the study considering accessibility of industries dealing with the selected products and their significance to the sustainability paradigm. In this regards, the study selected six (6) regions including Dar es Salaam, Arusha, Dodoma, Singida, Mwanza and Kagera.

Further, census procedure was involved during data collection from total of (123) eco-certified industries in the data base. The application of census is recommended by scholars particularly when the sampling list is involving few numbers of units (Kothari, 2004). However, during data collection, researchers managed to collect data from (104) accessible industries. These accessible industries indicated response rate of (84.5%) from the complete list of (123) eco-certified industries in the frame.

This study involved two categories of variables specifically independent and dependent variables. The independent variables involved drivers to the implementation of ecopreneurship practices which comprised of five latent factors namely; Finance, Knowledge, Internal Stakeholders, Motivation and Researches. The drivers were latent constructs and therefore they were measured through indicator variables. Respondents were asked to rate importance of indicator on a 5-point Likert type scale (from 1=Not Important to 5= Very Important) the response that best describes how much they regard on the importance of the driver on influencing their ecopreneurship implementation.

With respect to the dependent variable, the dependent variable involved ecopreneurship which was further classified into three types of practices namely; eco-opportunity (EO), eco-commitment (EC) and eco-innovation (EI). In addition, each type of ecopreneurship was measured through five indicator variables. In this regards, ecopreneurs were asked to respond on the statements that described type of activities implemented in their industries which describe implementation of ecopreneurship practices on 5-point Likert scale ranging from 1 = strongly disagree; 2 = Disagree; 3 = Neutral; 4 = Agree; and 5 = strongly agree.

The data analysis involved Structural Equation Modelling (SEM) through AMOS available in the Statistical Package for Social Science SPSS version 21. The analysis procedures were proceeding by measurements for reliability and validity. Reliability and validity are the foremost criteria used to assess the quality of research instruments. Regarding to reliability, two reliability components were addressed in this study namely; internal reliability and composite reliability. The internal reliability measured the consistency of results across items within the test and composite reliability measured the extent to which measures varies from one use to another. The internal reliability of the constructs has been measured through coefficient of Cronbach's alpha (α) where the threshold value being range from 0.70 and above (Cronbach, 1951). The results of the tests shown acceptable scores of ($\alpha > 0.7$) for all the measured constructs and thus established to be reliable tools employed in this study.

Furthermore, composite reliability was measured through confirmatory factor analysis CFA based on recommendation by scholars (Byrne, 2010). The results of the computation of the CFA revealed attainment of recommended threshold of points 0.3 and above for the loaded constructs. With regard to validity, this study measured three common validity methods that are mainly used to evaluate validity of measurements. The methods include content validity, criteria validity, and construct validity. In the content validity, research made a thorough review of literature so as to get a broader understanding of the concepts under the study. Furthermore, a depth review of experts' opinions from publications was conducted to ensure that all observed variables in the measurements are correctly and sufficiently represent the constructs in the study particularly on ecopreneurship, drivers for its implementation and sustainability of practicing.

Furthermore, the constructs validity includes several other forms of validity namely convergent and discriminant (Malhotra and Birks, 2007). The Confirmatory Factor Analysis (CFA) was conducted to address convergent validity and results were acceptable based on recommended factor loadings and average variance extracted (AVE) being greater than the threshold value of 0.50 (Kushwaha and Sharma, 2017). Additionally, the discriminant validity was conducted based on suggestion criterion by Fornell and Larcker (1981) where the AVE value of each construct required to exceed the squared correlation among other constructs in the model. The results of the tests shown AVE were greater than maximum shared variance (MSV) and therefore discriminant validity was attained.

The analysis through the SEM model followed basic steps of the SEM analysis process specifically involving specification, identification, measurement and structural model. Prior to the mentioned steps, the analysis began to fulfil important model assumptions which required to be fulfilled prior to analysis. Researchers ensured satisfaction of the following key assumptions including multivariate normality, absence of missing data, sufficiency sample size, and correct model specification, absence of outliers, absence of multicollinearity and absence of correlation between error terms.

3.1 Model specification

Model specification was developed based on theoretical and empirical literature review for the inferences on the appropriate variables and relationship among them. This study hypothesised model specification for SEM with two categories of variables namely exogenous and endogenous variables. The exogenous variables involved independent variables namely drivers for ecopreneurship implementation. This study aimed to measure the influence of drivers on the implementation of ecopreneurship practices.

The second categories of the model specification include exogenous variable specifically ecopreneurship practices. In this model, ecopreneurship was considered as dependent variable in the path diagram. Therefore, it was hypothesised that, ecopreneurship implementation was influenced by selected internal drivers shown in the Figures 2. Further, ecopreneurship was measured through three practices namely; Eco-Opportunity (EO), Eco-Commitment (EC) and Eco-Innovation (EI).



Figure 2: Model specification

3.2 Measurement Model

With respect to measurement model, the relationship between latent variables and their observed measure specifically conducted through Confirmatory Factor Analysis (CFA) shown in the Figure 3. In this regard, the measurement model for this study involved CFA in conjunction with several other test models which revealed satisfactory threshold particularly validity, reliability, normality of the data. The scores of the CFA indicated that, all constructs measured were significant and reached factor loadings of above 0.3 for satisfactory threshold as recommended by Tabachnick and Fidell (2007). Furthermore, the regression weight and squared multiple correlation (SMC) of the constructs revealed significance correlated to the specified construct and so construct validity was attained.

The subsequent measurement model involved model fitness test which was conducted for the purpose of determining fitness of the model on the data under the study. Therefore, several commonly used absolute fit measures were assessed during model fitness including the Relative Chi-Square (χ^2 / df), Goodness of Fit index (GFI), Adjusted Goodness of Fit Index (AGFI), Comparative Fit index (CFI), Incremental fit Index (IFI) and Root Mean Square error of approximation (RMSEA). The results of the tests shown attainment of fitness scores for the measurements model which was examined by the (CMIN/DF = 1.42), (GFI = 0.93), (AGFI = 0.93), (IFI = 0.98), and (RMSEA=0.06). Therefore, based on the results of the measurement model, the measurement constructs were considered satisfactory for the subsequent phase in the analysis specifically structural models.

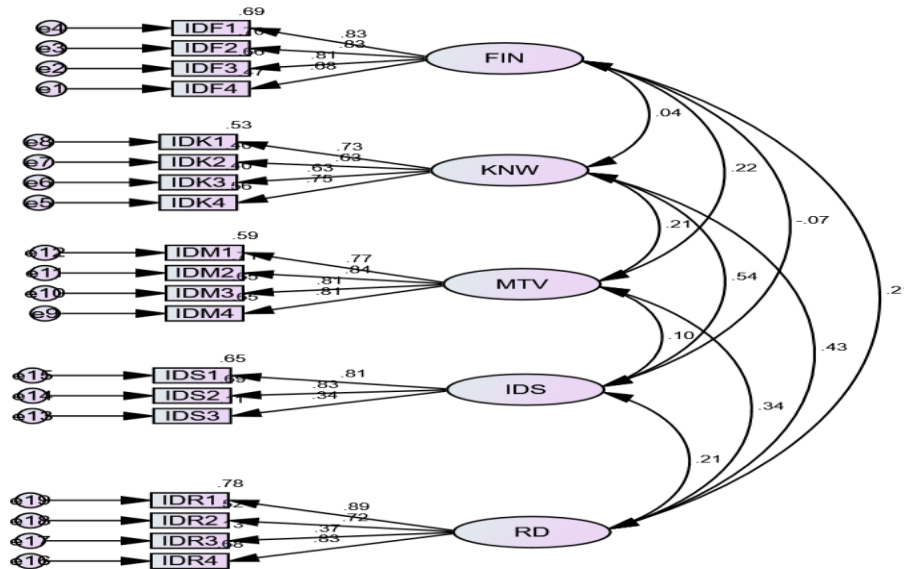

Figure 3: Measurement Model

4.0 FINDINGS

The study findings on the relationship between internal drivers on the implementation of ecopreneurship practices supports significances of finance, knowledge, internal stakeholders and research on influencing industries to implement ecopreneurship practices. In this regards, study findings informs small scale industries to enhance implementation of ecopreneurship through capitalising their finance, knowledge and researching on environmental matters. Further, the influence of stakeholders including employees and managers found to contribute significantly on ecopreneurship implementation.

This study was conducted to (102) ecopreneurial industries of the food and beverage sector operating in six regions of Tanzania mainland. Among the selected industries, about (45.1%) were manufacturers of food products which involved three types of food products namely, Oilseeds (10.8%), Dairy, tea and coffee (15.7%), in addition to the (18.6%) of the flour mill. Furthermore, the surveyed industries involved beverage products by (54.9%) from two major categories namely, drinking water (38.2%) and fruit drinks (16.7%). The distribution of surveyed industries based on regions were, Dar es Salaam (54.9%), Arusha (18.6%), Kagera (8.8%), Dodoma (6.9%), Mwanza (6.9%), and Singida (3.9%). The respondents who were involved in the survey were employed managers (92.2%) and owner managers (7.8%). The dominance of employed managers in the survey suggests their involvement in the regular industrial operations and willingness to participate in the investigation.

Regarding to the size of the industries, three categories of industries were involved based on classification provided in the Tanzania Small, Medium and Large Enterprise Development SMEs (2003). Based on this classification, size of the sampled industries comprised of (15.7%) of small industries, (72.5 %) were Medium industries and (11.8%) from large industries. In this regard, more than a half of surveyed industries were medium size. This suggests that majority of ecopreneurs in the selected food and beverage industries were medium size. Furthermore, all the selected industries had above three years of operations which was considered appropriate for understanding their involvement on implementing ecopreneurship practices. The details of the demographic information are presented in the Table 1.

Table1: Demographic Information of the Surveyed Industries

Particulars		Frequency	Percent (%)
Type of Industry	Food	46	45.1
	Beverage	56	54.9
	Total	102	100
Position of Respondents	Owner Manager	8	7.8
	Employed Manager	94	92.2
	Total	102	100
Size of the firm	Small	16	15.7
	Medium	74	72.5
	Large	12	11.8
	Total	102	100
Type of Product	Drinking water	39	38.2
	Fruit Drinks	17	16.7
	Oilseeds	11	10.8
	Dairy, Tea and Coffee	16	15.7
	Flour Mill	19	18.6
	Total	102	100
	Number of Industry in Region	Dar es Salaam	56
Dodoma		7	6.9
Singida		4	3.9
Arusha		19	18.6
Mwanza		7	6.9
Kagera		9	8.8
Total	102	100	
Years of experience in ecopreneurship	Above three years	102	100

4.1 Influence of Internal Drivers on the Implementation Ecopreneurship Practices.

The setting of the study objective hypothesised the relationship between internal drivers on the implementation of ecopreneurship practices. Thus, the study theorised the positive relationship between internal drivers on the implementation of ecopreneurship practices. The internal drivers were categorised into five latent constructs specifically finance, knowledge, motivation, research and stakeholders. The results of the multiple regression analysis presented in Table 2 and Figure 4 shows the findings of the analysis which measured the influence of drivers on implementation of ecopreneurship. The threshold for the significance of the hypothesised relationship being $(p) < 0.05$, and $C.R > 1.96$. In this regard, five null hypothesis were tested as follows:

H₀: There is no relationship between finance and implementation of ecopreneurship practices.

The results of the structural model in Table 2 shown that finance is related positively and significantly influence implementation of ecopreneurship where $(p) = 0.011$; $C.R = 2.531$ at the (β) value of 0.167. These results rejected null hypothesis and supported the hypothesised relationship of finance on implementation of ecopreneurship. In this

vein, findings suggest that, if financing environmental activities is improved by (1) standard deviation, the implementation of ecopreneurship increases by 16.7%. Therefore, the results inform industries on the strategies to enhance ecopreneurship implementation through financial investment in the activities related with eco-productions and eco-marketing.

H₀: There is no relationship between knowledge and implementation of ecopreneurship practices in the selected industries

Regarding knowledge, regression results indicated that knowledge is related positively and significantly influences implementation of ecopreneurship where $(p) = < 0.0001$; C.R = 4.582 at the (β) value of 0.522. These results rejected null hypothesis and supported the hypothesised relationship of knowledge on implementation of ecopreneurship. In this vein, findings suggest that if knowledge on environment is improved by (1) standard deviation, the industry implementation of ecopreneurship increases by 52.2%. Therefore, the results infer that investing on employee knowledge on ecopreneurship matters through training and development significantly influence implementation of ecopreneurship practices.

H₀: There is no relationship between internal stakeholders and implementation of ecopreneurship practices in the selected industries

Regarding internal stakeholders, regression results indicates that internal stakeholders are related positively and significantly influence implementation of ecopreneurship where $(p) = 0.007$; C.R = 2.708 at the (β) value of 0.565. These results rejected null hypothesis and supported the hypothesised relationship of internal stakeholders on implementation of ecopreneurship practices. In this vein, study findings suggests that if internal stakeholder concern on environment is improved by (1) standard deviation, the industry implementation of ecopreneurship increases by 56.5%. In this regards, the results asserts on the necessity of participation of internal stakeholders on influencing implementation of ecopreneurship practices, these stakeholders include employees, management and owners.

H₀: There is no relationship between motivation and implementation of ecopreneurship practices in the selected industries

Regarding motivation, regression results indicated the relationship is insignificant where $(p) = 0.372$; C.R = 0.892 at the (β) value of 0.053. Thus, the results failed to reject null hypothesis and therefore hypothesised relationship of motivation on the implementation of ecopreneurship is not supported. In other words, motivation does not influence industries to implement ecopreneurship practices.

H₀: There is no relationship between research and implementation of ecopreneurship practices in the selected industries

Regarding research, regression results indicate that research is related positively and significantly influences implementation of ecopreneurship where $(p) = < 0.0001$; C.R = 4.794 at the (β) value of 0.34. These results rejected null hypothesis and supported the hypothesised relationship of research on implementation of ecopreneurship. In this vein, findings suggest that if research on environment is improved by (1) standard deviation, the industry implementation of ecopreneurship increases by 34%. Therefore, the results inform industries to engage on the activities of eco-research and development in line with mechanism towards enhancing ecopreneurship implementation.

Table 2: The Influence of Internal Drivers on the Implementation of Ecopreneurship Practices.

Endogenous Variables	Exogenous Variables	Parameter Estimate (β)	Standard Error	C.R.	P-Value
Ecopreneurship	<--- Finance	0.167	0.066	2.531	0.011
Ecopreneurship	<--- Knowledge	0.522	0.114	4.582	< 0.0001
Ecopreneurship	<--- Stakeholders	0.565	0.208	2.708	0.007
Ecopreneurship	<--- Motivation	0.053	0.059	0.892	0.372
Ecopreneurship	<--- Researches	0.34	0.071	4.794	< 0.0001

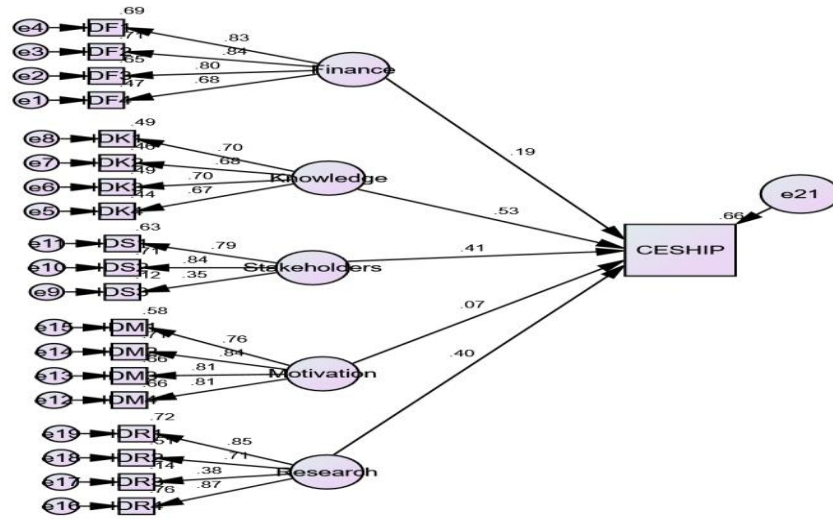

Figure 4: SEM output for structural Model

5.0 DISCUSSION

The main objective of this study was to investigate the influence of internal drivers on the implementation of ecopreneurship specifically to the three types of practices namely; eco-opportunity, eco-commitment and eco-innovation. The analysis was based on ecopreneurs operating in the Tanzania food and beverage products. The study findings indicated that finance, knowledge, internal stakeholders and research were significant drivers for the implementation of ecopreneurship practices. Conversely, findings have shown that motivation had insignificant influence on the implementation of ecopreneurship practices. Based on the study findings, it suggests that an increasing internal industrial capability in financing ecopreneurship activities may perhaps support to increase implementation of ecopreneurship. Similarly, the study findings suggest that increasing employee knowledge particularly on entrepreneurship and environment aspects may perhaps results into increasing industry implementation of ecopreneurship practices.

Furthermore, regarding involvement of internal stakeholders the study suggests that implementation of ecopreneurship practices can be increased through involvement of internal stakeholders which include employees, management and owners. These stakeholders have shown vital decisions regarding to the industry implementation of ecopreneurship practices. In addition, regarding the research activities, the study offers lessons regarding the importance of research and development activities on implementation of ecopreneurship. Thus, it is perhaps useful to increase research activities in order for the industries to gather useful information concerning ecopreneurship and therefore influence implementation of several practices of ecopreneurship.

In connection to these findings, there have been several other scholars with corresponding propositions from studies conducted in other context of nations. For instance, it was empirically asserted that financial capacity of firms has positive influence on the implementation of eco-related practices (Kubicka and Pachura, 2017). This argument is based on the facts that, ecopractices involves several costs such as technology, research and therefore funding such activities is essentially required. Furthermore, regarding knowledge, Shepherd and Patzelt (2015) depicted on the existence of environmental knowledge within firms as factor which increases capacity to implement eco-related practices. Also, other scholars have supported the importance of internal stakeholders including managers environmental capabilities on influencing ecopreneurship decisions (Pacheco *et al.*, 2017; Bossle, De-Barcellos, and Vieira, 2016).

Regarding to the positive influence of research and development on ecopreneurship implementation, several scholars including Triguero, Cuerva, and Álvarez-Aledo (2017) provided similar suggestions on the usefulness of

industrial capability in research activities for enabling ecopreneurship. Research and development activities usually gather and provide eco-related information such as availability and accessibility of eco-technology, eco-idea and products, as well as sources of eco-raw materials.

On the other hand, insignificance of motivation drivers on ecopreneurship implementation also correspond with other studies including Silverman *et al.*, (2005) in New Zealand and United States wine industry, the study found that motivation and external stakeholder pressures were not significant drivers in New Zealand whereas the same were found to be stronger determinants in United States wine industry. These findings from Silverman *et al.*, (2005) regarding insignificance of the motivation factors could also confirmed deduction from other researchers who have reported on the context-based drivers for ecopreneurship practices including (Bruin, 2016; Ceptureanu *et al.*, 2017). Therefore, it is not surprising that the motivation driver did not show significant influence in the context of this study setting.

6.0 CONCLUSION AND RECOMMENDATIONS

Given the ongoing global goals on sustainable development in the spheres of sustainable industrial practices several countries are committing efforts to enhance implementation of sustainable ecopreneurship practices particularly in industries. In this regard, ecopreneurship is considered to be essential sustainable industrial practices in the direction towards achievement of sustainability through environmentally friendly procedures in products, process, marketing and community services.

This research was directed to address the problem of sustainability through investigating the significant drivers for the implementation of ecopreneurship practices particularly among selected food and beverage industries in Tanzania. This study was based on ecopreneurs operating in the Tanzania food and beverage industry being an important sub-sector due to products directly accountable for human health and diversity of industrial establishments in the Tanzania economy.

The study findings conclude that, implementation of ecopreneurship is significantly influenced by internal drivers finance, knowledge, internal stakeholders and researches. The study results provides additional insights through empirical evidence concerning to the influence of identified drivers namely; finance, knowledge, stakeholders and researches on implementation of ecopreneurship in the context of this study. Furthermore, in connection to the status of limited implementation of ecopreneurship in Tanzania, the study findings provides practical lessons to the initiatives intended to enhance implementation of ecopreneurship based on the significances of drivers'. Along these lines, workable initiatives towards enhancing ecopreneurship implementation can be undertaken by concentrating on the significant drivers. This significant driver consists of finance, knowledge, stakeholders and researches.

With regard to limitation of the study, the scope of this study was based on Tanzania food and beverage industries. In this regards, further research can be directed to other context of nations particularly to other African states in the direction toward empirical validation of the significant internal drivers on the implementation of ecopreneurship practices. The question we raised is on whether these countries with similar level of industrial development have comparable characters on internal industrial capabilities influencing ecopreneurship implementation. And, in case of dissimilarities, what lessons has to be learnt in relation to the initiatives directed to enhance ecopreneurship implementation.

Furthermore, this study was specifically set to analyse industry implementation capabilities by focusing on internal capabilities of industries, nevertheless for robust understanding, we suggests future studies to investigate how external factors and pressures from environmentalist influence industries decisions to implement ecopreneurship. This perspective is grounded on several external initiatives which have been undertaken at the global perspective to enhance ecopreneurship implementation such as environmental policies, regulations and support from external environmental organisations. It is therefore, necessary to investigate influences of such external factors in enhancing ecopreneurship implementation particularly among countries on the stage of industrial development in several African states including Tanzania.

REFERENCES

Antolin-Lopez, R., Martinez-del-Rio, J., and Cespedes-Lorente, J. J. (2019). Environmental entrepreneurship as a multi-component and dynamic construct: Duality of goals, environmental agency, and environmental value creation. *Business Ethics: A European Review*, 28(4), 407-422.

- Bossle, M. B., De Barcellos, M. D., and Vieira, L. M. (2016). Why food companies go green? The determinant factors to adopt eco-innovations. *British Food Journal*.
- Bruin, A. (2016). Towards a framework for understanding transitional green entrepreneurship. *Small Enterprise Research*, 23(1), 10-21.
- Byrne, B. M. (2010). Structural equation modeling with AMOS: basic concepts, applications, and programming (multivariate applications series). *New York: Taylor and Francis Group*, 396(1), 7384.
- Ceptureanu, E. G., Ceptureanu, S. I., Orzan, M. C., Bordean, O. N., and Radulescu, V. (2017). Empirical study on sustainable opportunities recognition. a polyvinyl chloride (PVC) joinery industry analysis using augmented sustainable development process model. *Sustainability*, 9(10), 1779.
- Cronbach, L. (1951). Coefficient alpha and the internal structure of tests. *Psychometrika*, 16(3), 247–334.
- Del Río, P., Romero-Jordán, D., and Peñasco, C. (2017). Analyzing firm-specific and type-specific determinants of eco-innovation. *Technological and Economic Development of Economy*, 23(2), 270-295.
- Fayiga, A. O., Ipinmoroti, M. O., and Chirenje, T. (2018). Environmental pollution in Africa. *Environment, development and sustainability*, 20(1), 41-73.
- Fornell, C., and Larcker, D. F. (1981). Evaluating structural equation models with unobservable variables and measurement error. *Journal of marketing research*, 18(1), 39-50.
- Haldar, S. (2019). Towards a conceptual understanding of sustainability-driven entrepreneurship. *Corporate Social Responsibility and Environmental Management*, 26(6), 1157-1170.
- Han, Z., Wang, Q., and Yan, X. (2019). How responsible leadership motivates employees to engage in organizational citizenship behavior for the environment: A double-mediation model. *Sustainability*, 11(3), 605.
- Hens, L., Block, C., Cabello-Eras, J. J., Sagastume-Gutierrez, A., Garcia-Lorenzo, D., Chamorro, C., and Vandecasteele, C. (2018). On the evolution of “Cleaner Production” as a concept and a practice. *Journal of cleaner production*, 172, 3323-3333.
- Hörisch, J. (2015). The role of sustainable entrepreneurship in sustainability transitions: A conceptual synthesis against the background of the multi-level perspective. *Administrative Sciences*, 5(4), 286-300.
- Huber, J. (2000). Towards industrial ecology: sustainable development as a concept of ecological modernization. *Journal of environmental policy and planning*, 2(4), 269-285.
- Barney, J., Wright, M., and Ketchen Jr, D. J. (2001). The resource-based view of the firm: Ten years after 1991. *Journal of management*, 27(6), 625-641.
- Index, E. P. (2018). Environmental performance index. *Yale University and Columbia University: New Haven, CT, USA*.
- Kushwaha, G. S., and Kumar Sharma, N. (2017). Factors Influencing Young Entrepreneurial Aspirant’s Insight towards Sustainable Entrepreneurship. *Iranian Journal of Management Studies*, 10(2), 435-466.
- Ljungkvist, T., and Andersén, J. (2021). A taxonomy of ecopreneurship in small manufacturing firms: A multidimensional cluster analysis. *Business Strategy and the Environment*, 30(2), 1374-1388.
- Longhofer, W., and Jorgenson, A. (2017). Decoupling reconsidered: Does world society integration influence the relationship between the environment and economic development?. *Social Science Research*, 65, 17-29.
- Malhotra, N. K., and Birks, D. (2007). *Marketing Research, An Applied Approach*, European Edition.
- Mwegoha, W. J. S., and Kihampa, C. (2010). Heavy metal contamination in agricultural soils and water in Dar es Salaam city, Tanzania. *African Journal of Environmental Science and Technology*, 4(11), 763-769.
- Ociepa-Kubicka, A., and Pachura, P. (2017). Eco-innovations in the functioning of companies. *Environmental research*, 156, 284-290.
- Pacheco J, D. A., Carla, S., Jung, C. F., Ribeiro, J. L. D., Navas, H. V. G., and Cruz-Machado, V. A. (2017). Eco-innovation determinants in manufacturing SMEs: Systematic review and research directions. *Journal of Cleaner Production*, 142, 2277-2287.
- Panackal, N., Singh, D. A., and Sharma, A. (2016). Developing a Conceptual Framework on Ecopreneurs and Sustainability Using ISM and MICMAC Methodology. *Nature Environment and Pollution Technology*, 15(4).
- Pushpakumara, W. H., Atan, H., Khatib, A., Azam, S. F., and Tham, J. (2019). Developing a Framework for Scrutinizing Strategic Green Orientation and Organizational Performance with Relevance to the Sustainability of Tourism Industry. *European Journal of Social Sciences Studies*.
- Rusmini, R., Taufikurohmah, T., and Sianita, M. M. (2019). Theoretical and Empirical Validity of Student Work Sheets to Train Eco Innovation in the Study of Food Analysis. In *National Seminar on Chemistry 2019 (SNK-19)* (pp. 143-147). Atlantis Press.
- Santini, C. (2017). Ecopreneurship and ecopreneurs: Limits, trends and characteristics. *Sustainability*, 9(4), 492.
- Schaltegger, S. (2002). A framework for ecopreneurship: Leading bioneers and environmental managers to

- ecopreneurship. *Greener management international*, (38), 45-58.
- Schumpeter, J. (1934). *The theory of economic development*. Cambridge: Harvard University Press.
- Shepherd, D. A., and Patzelt, H. (2015). Harsh evaluations of entrepreneurs who fail: the role of sexual orientation, use of environmentally friendly technologies, and observers' perspective taking. *Journal of Management Studies*, 52(2), 253-284.
- Silverman, M., Marshall, R. S., and Cordano, M. (2005). The greening of the California wine industry: Implications for regulators and industry associations. *Journal of Wine Research*, 16(2), 151-169.
- Tabachnick, B., Fidell, L. S., and Ullman, J. B. (2007). *Using multivariate statistics*. Boston, MA: Pearson Education.
- Triguero, Á., Cuerva, M. C., and Álvarez-Aledo, C. (2017). Environmental innovation and employment: Drivers and synergies. *Sustainability*, 9(11), 2057.
- United Nations Assembly, G. (2015). Sustainable development goals. *SDGs Transform Our World, 2030*.
- URT. (2017). *Environmental consideration for sustainable industrialization in Tanzania*. Dar es Salaam.
- URT. (2018). *Situational analysis of the implementation of national environmental policy (1997) The Vice President Office*. Dodoma.
- Wangwe, S., Mmari, D., Aikaeli, J., Rutatina, N., Mboghoina, T., Abel, and Kinyondo. (2014). The Performance of the Manufacturing Sector in Tanzania: Challenges and the Way Forward. In *Learning to Compete* (No. 22). Dar Es Salaam.
- Zangirolami-Raimundo, J., Echeimberg, J. D. O., and Leone, C. (2018). Research methodology topics: Cross-sectional studies. *Journal of Human Growth and Development*, 28(3), 356-360.
- Zhang, F., and Zhu, L. (2019). Enhancing corporate sustainable development: Stakeholder pressures, organizational learning, and green innovation. *Business Strategy and the Environment*, 28(6), 1012-1026.